

VERSION	00	02/2014	First version
----------------	----	---------	---------------

Document no.	LVT-TI2014-05-00-Routine maintenance- critical components list-EN
Brand	SMEG
Models involved	<p>WD4060R, WD4060, WD4060D1, WD4060D, WD4060-1, WD4060-6, WD4060R6,</p> <p>WD1160R, WD1160D, WD1160, WD1160D1, WD1160-1, WD1160-3, WD1160R1</p> <p>GW4060C, GW4060SC, GW4060, GW4060S, GW4060-1, GW4060S6, GW4060S1, GW4060SC1, GW4060-6</p> <p>GW1160SC6, GW1160SC, GW1160, GW1160S, GW1160C, GW1160-1, GW1160-6, GW1160-16, GW1160-36, GW1160C6</p>
Cause	-----
Description of the modification	Requirements for technical assistance service, routine maintenance.
Introduction date	-
Interchangeability	-

1 ROUTINE MAINTENANCE

Here below are summarized the requirements in the manual of the device for guiding the technician in the essential routine maintenance operations at the recommended intervals: yearly.



Maintenance operations are not covered by the Warranty of the product, which does not include the replacement of components whose performance loss is due to normal wear or use.





Operations to be carried out:



1. Check and replacement of worn parts of **peristaltic pumps** (especially the inner tube).
2. Check the good condition and replacement of the **detergent suction tubes**.
3. Check the good condition and replacement of the **door seal**.
4. Check the good condition and replacement of the **filters** (relative and absolute) of the **drying system**.
5. Check and, if necessary clean/replace the **filters** (water inlet filter on the fill hose, detergentss filter on the intake systems).
6. Check the **water hardness setting** on the input (the infill water characteristics check must be made in advance, by the user, for a correct setting).
7. Check the correct **setting of detergent dosing**.
8. Check the steam **condenser assembly**:
 - a. Check the **nozzles**, verify the proper water flow.
 - b. check the connecting **pipes** for water loading, water unloading, connection to the level pressure switch.
9. **Execution of a complete operation cycle** comprising the drying phase to check for leaks or malfunctions.

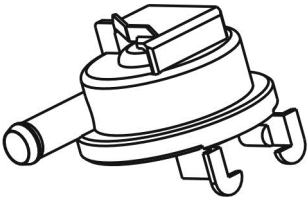
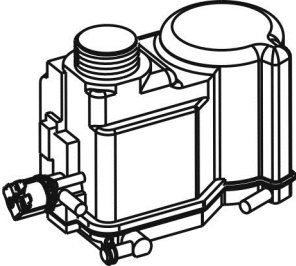
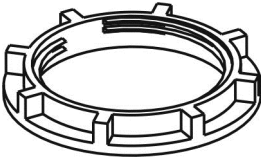
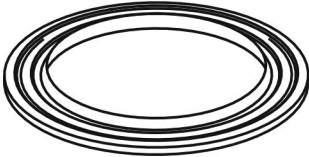

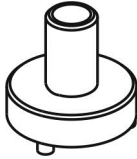
2 TABLE OF RECOMMENDED PERIODIC REPLACEMENTS

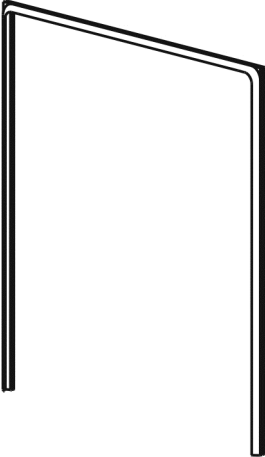

Below is given a description of the parts to replace, the indicative image and the position number in the exploded drawing.

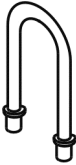
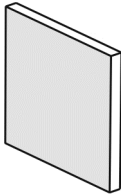
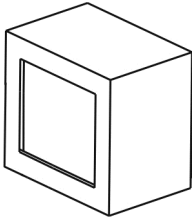
NOTE: refer to the spare parts catalogs on the Web, to identify the correct updated part number.

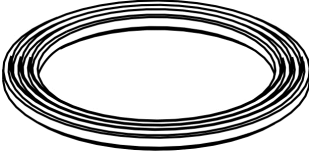
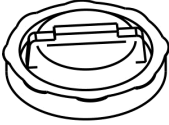
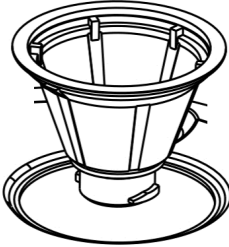
DESCRIPTION	IMAGE IN THE EXPLODED DRAWING	yearly	every 2 years	every 3 years
WATER INTAKE TURBINE FLOW METER (COLD/DEMINERALIZED) Component pos. no in the exploded drawing: 61093				X
WATER SOFTENER Component pos. no in the exploded drawing: 698				X
WATER SOFTENER FASTENING RING NUT Component pos. no in the exploded drawing: 696				X
WATER SOFTENER GASKET Component pos. no in the exploded drawing: 697		X		
WATER SOFTENER CAP Component pos. no in the exploded drawing: 695				X
DETERGENTS SUCTIONS FILTER Component pos. no in the exploded drawing: 923			X	
DETERGENTS "RED" SILICONE HOSE (ACID NEUTRALIZING AGENT) Component pos. no in the exploded drawing: 3358			X	
DETERGENT "NEUTRAL" SILICONE HOSE Component pos. no in the exploded drawing: 1357			X	

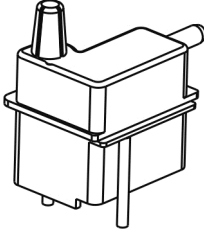
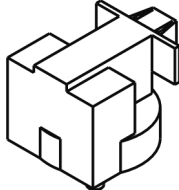
DESCRIPTION	IMAGE IN THE EXPLODED DRAWING	yearly	every 2 years	every 3 years
DETERGENTS FLOW METER Component pos. no in the exploded drawing: 706				X
TUB GASKET Component pos. no in the exploded drawing: 25109			X	
WASHING PUMP ROTATING GASKET Component pos. no in the exploded drawing: 89781			X	
PERISTALTIC PUMP INNER TUBE (for each peristaltic pump installed on the model) Component pos. no in the exploded drawing: 750			X	
DRYING PRE-FILTER (where the drying system is present) Component pos. no in the exploded drawing: 807		X		
DRYING ABSOLUTE FILTER (if present) Component pos. no in the exploded drawing: 805		X		

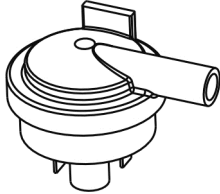
DESCRIPTION	IMAGE IN THE EXPLODED DRAWING	yearly	every 2 years	every 3 years
FLOW RATE REGULATOR (RED ELEMENT IN THE TANK) Component pos. no in the exploded drawing: 7158			X	
ROOF SUPPLY HOSE GASKET Component pos. no in the exploded drawing: 2234		X		
GASKET FOR WATER INTAKE HOSE Component pos. no in the exploded drawing: 1623			X	
SUMP WASHING FILTER Component pos. no in the exploded drawing: 26097			X	
DRAIN PUMP FILTER Component pos. no in the exploded drawing: 26098				X
AIR TRAP Component pos. no in the exploded drawing: 27368			X	
"PLA" ANALOGUE PRESSURE SWITCH (ASSEMBLED ON FRONT CROSSBAR) Component pos. no in the exploded drawing: 83940				X

DESCRIPTION	IMAGE IN THE EXPLODED DRAWING	yearly	every 2 years	every 3 years
<p>"PAP" HIGH PRESSURE PRESSURE-SWITCH Component pos. no in the exploded drawing: 90393</p>				X
<p>STEAM CONDENSER NOZZLES AND GASKETS Component pos. no in the exploded drawing: 867 / 3571 (according to the model)</p>				X